



C 34V

AUDIO/VIDEO
CONTROL CENTER

McIntosh®

OWNERS MANUAL

IMPORTANT SAFETY INSTRUCTIONS

THESE INSTRUCTIONS ARE TO PROTECT YOU AND THE MCINTOSH INSTRUMENT. BE SURE TO FAMILIARIZE YOURSELF WITH THEM.

1. Read all instructions - Read the safety and operating instructions before operating the instrument.
2. Retain Instructions - Retain the safety and operating instructions for future reference.
3. Heed warnings - Adhere to warnings and operating instructions.
4. Follow Instructions - Follow all operating and use instructions.
WARNING: TO REDUCE RISK OF FIRE OR ELECTRICAL SHOCK, DO NOT EXPOSE THIS INSTRUMENT TO RAIN OR MOISTURE.
5. Power Sources - Connect the power supply only to the type described in the operating instructions or as marked on the unit.
6. Power-Cord Protection - Route power-supply cords so that they are not likely to be walked on or pinched by items placed upon or against them, paying particular attention to cords at plugs, convenience receptacles, and the point where they exit from the instrument.
7. Ventilation - Locate the instrument for proper ventilation. For example, the instrument should not be placed on a bed, sofa, rug, or similar surface that may block ventilation openings; or, placed in a built-in installation, such as a bookcase or cabinet, that may impede the flow of air through the ventilation openings.
8. Heat - Locate the instrument away from heat sources such as radiators, heat registers, stoves, or other appliance (including amplifiers) that produce heat.
9. Wall or Cabinet Mounting - Mount the instrument in a wall or cabinet only as described in the owners manual.
10. Water and Moisture - Do not use the instrument near water - for example, near a bathtub, washbowl, kitchen sink, laundry tub, in a wet basement, or near a swimming pool, etc.
11. Cleaning - Clean the instrument by dusting with a dry cloth. Clean the panel with a cloth moistened with a window cleaner.
12. Object and Liquid Entry - Do not permit objects to fall and liquids to spill into the instrument through enclosure openings.

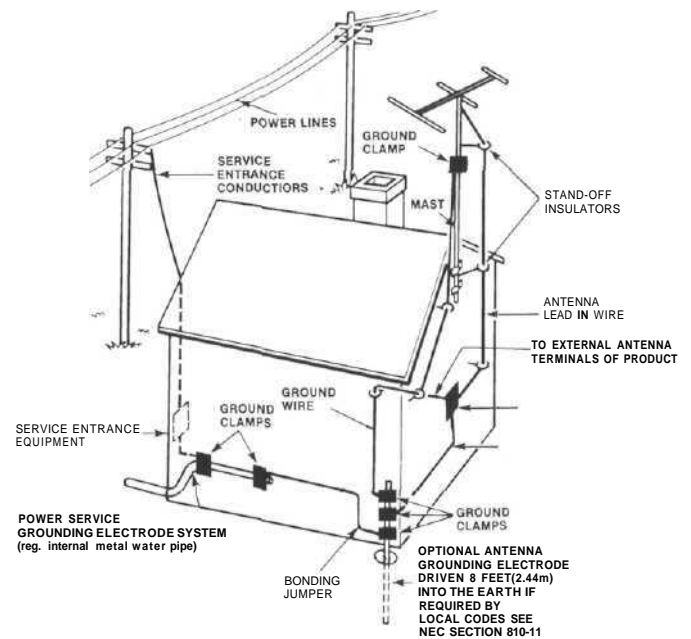

13. Power Lines - Locate any outdoor antenna away from power lines.
14. Outdoor Antenna Grounding - If an outdoor antenna is connected to the antenna terminal, be sure the antenna system is grounded to provide some protection against voltage surges and built up static charge.
In the U.S.A., section 810 of the National Electrical Code, ANSI/NFPA No. 70-1987, provides information on the proper ground for the mast and supporting structure, ground for the lead-in wire to an antenna discharge unit, and size of ground conductors, location of antenna-discharge unit, connection to grounding electrodes, and requirements for the grounding electrode.
For ground wire:
 - a) Use No. 10 AWG (5.3 mm²) copper, No. 8 AWG (8.4 mm²) aluminum, No. 17 AWG (1.0 mm²) copper-clad steel, bronze wire, or larger as ground wire.
 - b) Secure antenna lead-in and ground wires to house with stand-off insulators spaced from 4 feet (1.22 meters) to 6 feet (1.83 meters) apart.
 - c) Mount antenna discharge unit as closely as possible to where lead-in enters house.
 - d) Use jumper wire not smaller than No. 6 AWG (13.3 mm²) copper or equivalent when separate antenna grounding electrode is used.

- 15. Nonuse Periods - Unplug the power cord from the AC power outlet when left unused for a long period of time.
- 16. Damage Requiring Service - **Service must be** performed by qualified service personnel when:
 - A. The power supply cord or the plug has been damaged; or
 - B. Objects have fallen, or liquid has been spilled into the instrument; or
 - C. The instrument has been exposed to rain; or
 - D. The instrument does not appear to operate normally or exhibits a marked change in performance; or
 - E. The instrument has been dropped, or the enclosure damaged.
- 17. Servicing - Do not attempt to service beyond that described in the operating instructions. All other service should be referred to qualified service personnel.
- 18. Grounding or Polarization - Do not defeat the inherent design features of the polarized plug. Non-polarized line cord adaptors will defeat the safety provided by the polarized AC plug.

19. **CAUTION: TO PREVENT ELECTRICAL SHOCK DO NOT USE THIS (POLARIZED) PLUG WITH AN EXTENSION CORD, RECEPTACLE OR OTHER OUTLET UNLESS THE BLADES CAN BE FULLY INSERTED TO PREVENT BLADE EXPOSURE.**

Note to CATV system installer:
 This reminder is provided to call the CATV system installer's attention to Article 820-22 of the NEC that provides guidelines for proper grounding and, in particular, specifies that the cable ground shall be connected to the grounding system of the building, as close to the point of cable entry as practical.

ATTENTION: POUR PREVENIR LES CHOCS ELECTRIQUES PAS UTILISER CETTE FICHE POLARISEE AVEC UN PROLONGATEUR, UNE PRISE DE COURANT OU UNE AUTRE SORTIE DE COURANT, SAUF SI LES LAMES PEUVENT ETRE INSEREES A FOND SANS EN LAISSER AUCUNE PARTIE A DECOUVERT.



The lightning flash with arrowhead, within an equilateral triangle, is intended to alert the user to the presence of uninsulated "dangerous voltage" within the product's enclosure that may be of sufficient magnitude to constitute a risk of electric shock to persons.



CAUTION: TO PREVENT THE RISK OF ELECTRIC SHOCK, DO NOT REMOVE COVER (OR BACK). NO USER-SERVICABLE PARTS INSIDE. REFER SERVICING TO QUALIFIED PERSONNEL.



The exclamation point within an equilateral triangle is intended to alert the user to the presence of important operating and maintenance (servicing) instructions in the literature accompanying the appliance.

The serial number, purchase date, and McIntosh Laboratory Service Contract number are important to you for possible insurance claim or future service. Record this information here.

Serial Number

Purchase Date

Service Contract Number

Upon application, McIntosh Laboratory provides a Service Contract to the original purchaser. Your McIntosh Authorized Service Agency can expedite repairs when you provide the Service Contract with the instrument for repair.

Contents

INTRODUCTION	4
SIMPLIFIED BLOCK DIAGRAM	5
INSTALLATION	6, 7
HOW TO CONNECT	8, 9, 10
FRONT PANEL CONTROLS USING THE PUSHBUTTONS	11, 12, 13
PERFORMANCE LIMITS	15
PERFORMANCE CHARTS	16, 17
TECHNICAL DESCRIPTION BLOCK DIAGRAM	18, 19
	20, 21

Your C 34V Audio/Video Control Center will give you many years of satisfactory performance. If you have any questions, please contact:

CUSTOMER SERVICE
McIntosh Laboratory Inc.
2 Chambers Street
Binghamton, New York 13903-9990
Phone: 607-723-3512

**Take Advantage of 3 years
of Contract Service...
Fill in the Application NOW.**

MCINTOSH THREE YEAR SERVICE CONTRACT

An application for A THREE YEAR SERVICE CONTRACT is included with this manual.

The terms of the contract are:

1. If the instrument covered by this contract becomes defective, McIntosh will provide all parts, materials, and labor needed to return the measured performance of the instrument to the original performance limits free of any charge. The service contract does not cover any shipping costs to and from the authorized service agency or the factory.
2. Any McIntosh authorized service agency will repair all McIntosh instruments at normal service rates. To receive the free service under the terms of the service contract, the service contract certificate must accompany the instrument when taken to the service agency.
3. Always have service done by a McIntosh authorized service agency. *If the instrument is modified or damaged as a result of unauthorized repair the service contract will be cancelled.* Damage by improper use or mishandling is not covered by the service contract.
4. The service contract is issued to you as the original purchaser. To protect you from misrepresentation this contract cannot be transferred to a second owner.
5. Units in operation outside the United States and Canada are not covered by the McIntosh Factory Service Contract, irrespective of the place of purchase. Nor are units acquired outside the USA and Canada, the purchasers of which should consult with their dealer to ascertain what, if any, service contract or warranty may be available locally.



LISTEN
VOR/T1 TV CD
VOR/T2 TUNER
LASER/T3 PHONO

MODE SELECTOR
STEREO REV STEREO MONO (L+R)
R TO L/R L-R TO L
L TO L/R L+R TO R

EQUALIZER FREQUENCY
30 150 500 1500 10k

VOLUME

RECORD
VOR/T1 TV CD
VOR/T2 TUNER
LASER/T3 PHONO

McIntosh C34V AUDIO/VIDEO CONTROL CENTER

IN TAPS OUT
L/S REC COMPANDOR REC EQUAL REC MONITOR L/F FILTERS HP 1 2 SPEAKER OUTPUT ON POWER HEAD PHONES

COMPANDOR RATIO
1.0 1.1 1.2 1.3 1.4 1.5 1.6 1.7 1.8
EXPAND OFF COMPRESS

BALANCE LOUDNESS
L R
FLAT MAX PANLOC

This manual will help you to install, operate, and understand your Audio/Video Control Center. Read it and become familiar with it to enjoy it to the fullest.

McIntosh has earned world renown for its technological contributions for improved sound. When you bought McIntosh, you bought not only high technology, you bought technological integrity proven by time. The McIntosh Audio/Video Control Center is the newest evidence of McIntosh technological integrity.

Music reproducing instruments that carry the McIntosh name have always been designed for technological leadership and to maintain the McIntosh reputation for best sound, for durability, and for long life. McIntosh has always earned the foremost reputation for quality performance. McIntosh has provided user oriented facilities and appearance and McIntosh design always provides for ease of maintenance or repair. These fundamental elements are incorporated in the McIntosh Audio/Video Control Center, the easiest to operate yet most complex ever.

Your McIntosh C 34V Audio/Video Control Center, above all others will deliver to you the best sound, the most flexibility, and the greatest ease of use.

The McIntosh C 34V is a superb quality, high performance Audio control center. With the MVS-1 Video Selector, the C 34V will provide both audio and video control.

The C 34V has many useful features to enhance your listening and video enjoyment. They include:

1. A dual preamplifier system that provides separate listen and record program control. You may listen to or view one program while you are recording a different program. With the McIntosh MVS-1 Video Selector, the C 34V will switch video and audio signals for viewing, listening, and recording.
2. Two independent, seven source input selector switches permit different audio (or video with the MVS-1) programs to be selected.
3. A low noise, electronic input switching system adjacent to the input jacks gives greater source to source isolation, low audio distortion, and freedom from noise and hum pick-up. The input selector electronic switching signals control the video switching in the MVS-1.
4. The record monitor switch allows the recorded program to be heard through the MAIN output, and, with the MVS-1, the recorded video signals to be seen on a TV or monitor.
5. A five band program equalizer adjusts and improves the loudness contrast of the five most important frequency ranges. Musical balance can be adjusted to compensate for listener preferences.
6. A precision output volume control is electronically trimmed during manufacture to maintain channel balance accuracy to a fraction of a decibel (dB). This high order of accuracy assures continuing program balance as the volume is changed.
7. An active circuit loudness control, is electrically independent of the volume control. Close conformity to the Fletcher-Munson equal loudness curves can be attained, regardless of the volume control position.
8. High and low frequency filters reduce high frequency noise and low frequency rumble at a 12 dB per octave roll off rate.
9. A compandor expands or compresses the dynamic range of the program material. Compressed recordings and broadcasts can be expanded to restore dynamic range. Tapes can be compressed and replayed using expansion to improve signal-to-noise ratio.
10. Front panel tape recorder jacks which allow simple plug-in of an additional tape recorder without disconnecting your regular system.

4 INTRODUCTION

SIMPLIFIED BLOCK DIAGRAM 5

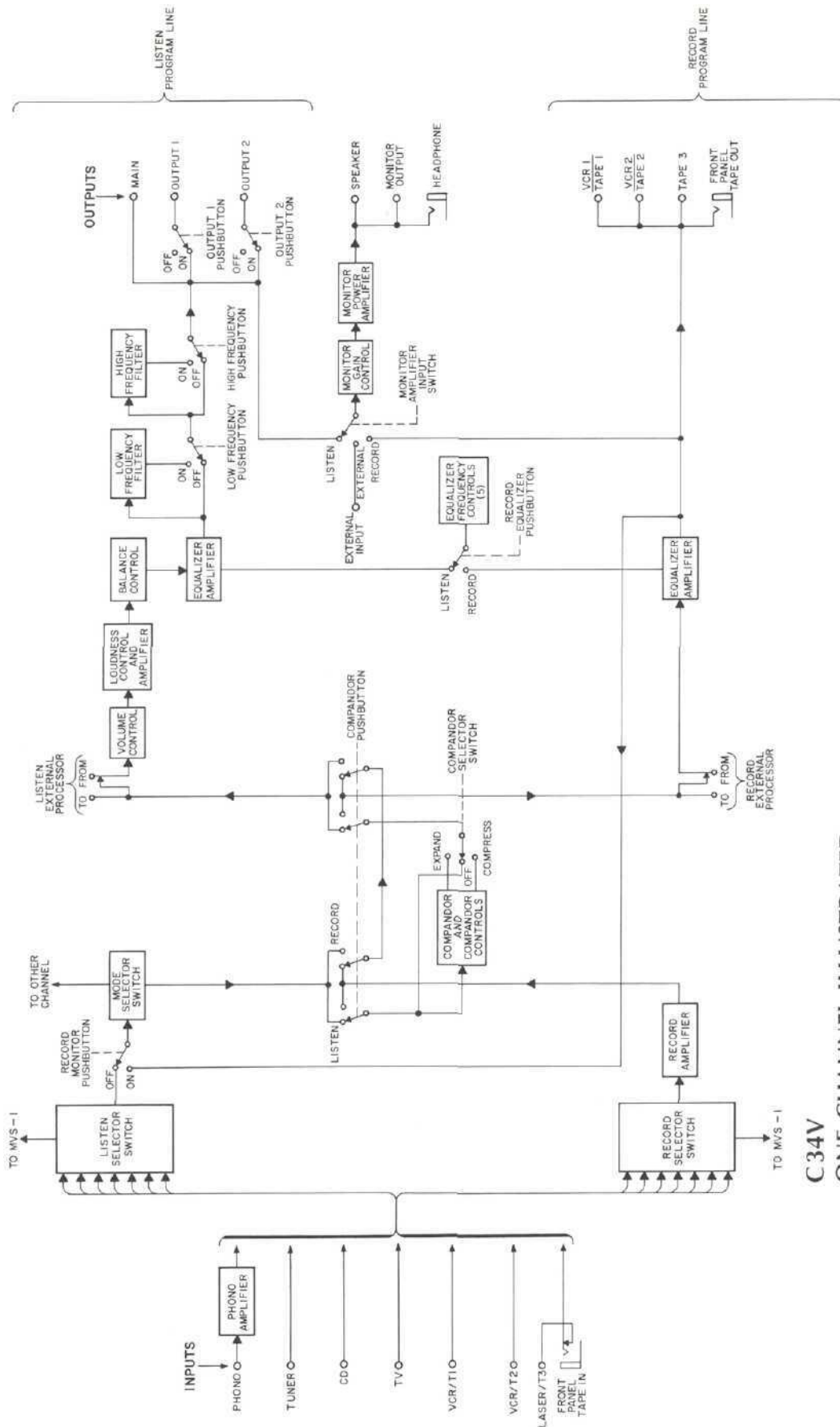

C34V
ONE CHANNEL ILLUSTRATED

PLAYER LOCATION

The C34V may be installed in a McIntosh cabinet or custom installed in furniture of your choice. Always provide adequate ventilation. The trouble-free life of an electronic instrument is greatly extended by providing sufficient ventilation to prevent the buildup of high internal temperatures that cause deterioration. Allow enough clearance so that cool air can enter at the bottom of the cabinet and be vented from the top. The recommended minimum space for installation is 15 5/8 inches (39.7 cm) deep, 17 inches (43.2 cm) wide, and 8 inches (20.32 cm) high. Never place it above heat generating components.

CUSTOM INSTALLATION

The PANLOC system of installing equipment conveniently and securely, is a product of McIntosh research. The PANLOC buttons on the front panel will lock the unit firmly in place when turned approximately one-quarter turn clockwise. A one-quarter counterclockwise turn of the PANLOC buttons unlocks the chassis from its mounting.

To install the instrument in a McIntosh cabinet, follow the instructions that are enclosed with the cabinet. For any other type of installation follow these instructions:

1. Unpack from Carton

Open the carton and remove the PANLOC brackets, hardware package, and mounting template. Remove the instrument from its plastic bag and place it upside down on the shipping pallet. Unscrew the four plastic feet from the bottom of the chassis.

2. Mark the Cabinet Panel

Tape the mounting template in position on the cabinet panel where the instrument is to be

installed. The broken lines that represent the outline of the rectangular cutout also represent the outside dimensions of the chassis. Make sure these lines clear shelves, partitions, or any equipment. With the template in place, first mark the six A and B holes and the four small holes that locate the corners of the cutout. Then, join the four corner markings with pencil lines, using the edge of the template as a straightedge.

3. Drill Holes

Use a drill with a 3/16 inch (5 mm) bit held perpendicular to the panel and drill the six A and B holes. Then, using a drill bit slightly larger than the tip of your saw blade, drill one hole at each of two diagonally opposite corners. The holes should barely touch the inside edge of the penciled outline. Before taking the next step, make sure that the six A and B holes have been drilled.

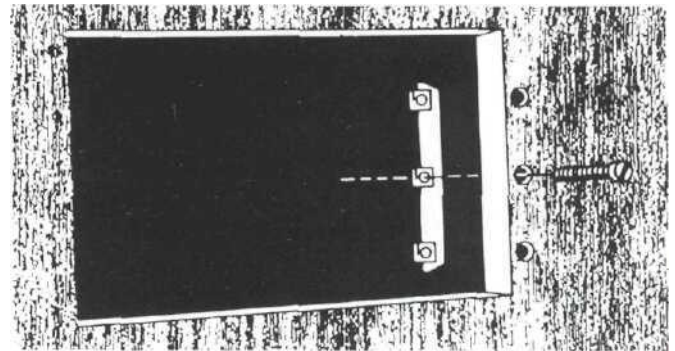

4. Saw the Panel Cutout

Saw carefully on the inside of the penciled lines. First make the two long cuts and then the two short cuts. After the rectangular opening has been cut out, use a file to square the corners and smooth any irregularities in the cut edges.

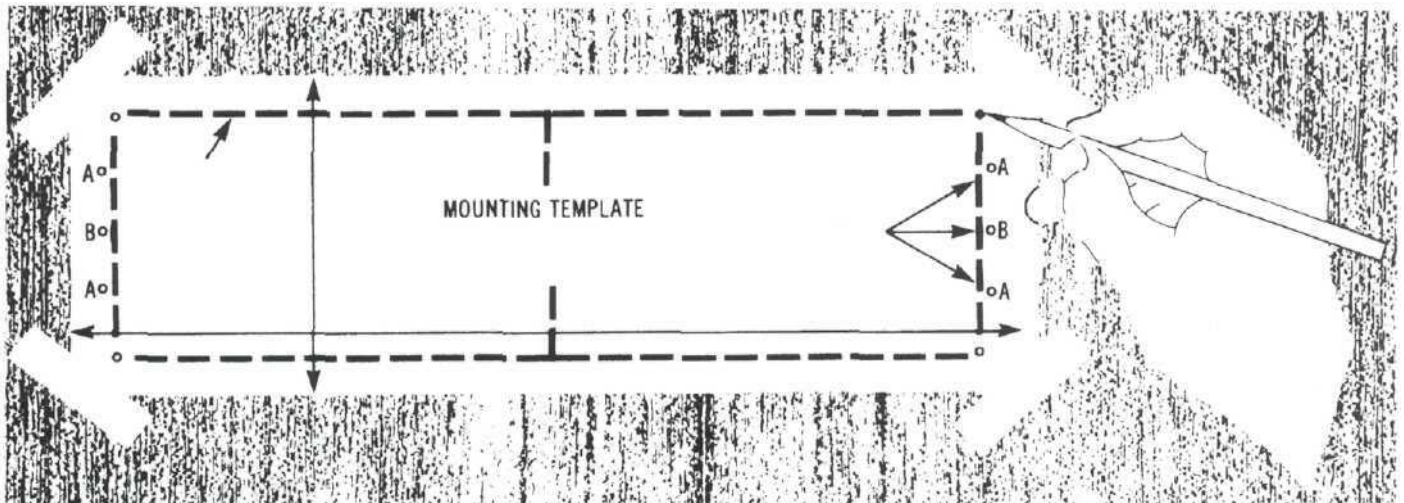

6 INSTALLATION

5. Install the Mounting Strips

In the hardware package you will find two mounting strips, and two sets of machine screws. For panels that are less than 1/2 inch (12.7 mm) thick, use the 3/4 inch (19.1 mm) screws; for panels that are more than 1/2 inch (12.7 mm) thick, use the 1-1/4 inch (31.8 mm) screws.

Starting at the right-hand side of the panel, insert a screw of the proper length into the center hole in the panel, marked B on the template. On the back of the panel, align a mounting strip with the holes in the panel and tighten the screw until the screwhead is pulled into the wood.

Repeat this procedure to attach the mounting strip to the left side of the panel.

6. Attach the PANLOC Brackets

Using two screws of the proper length in the A holes on each side, attach the PANLOC brackets to the cabinet panel; the short flange is mounted against the front (face) of the cabinet panel. The screws pass through the PANLOC bracket flange, the cabinet panel, and then through the mounting strips previously mounted.

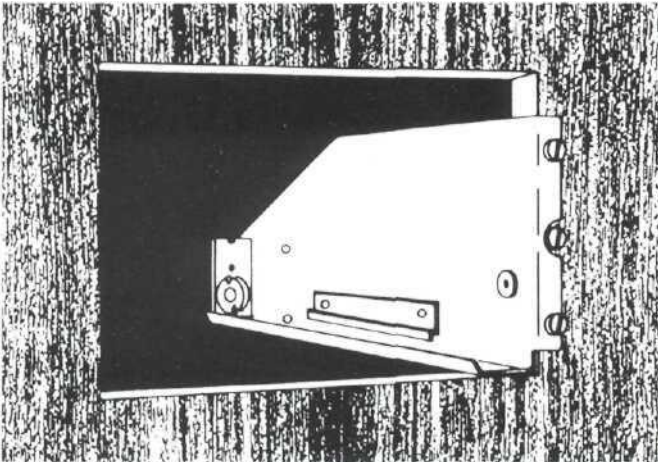

7. Install the Instrument

Guide the AC power cord through the panel opening to the back of the cabinet; then, slide the instrument into the opening carefully so that the rails on the bottom of each side of the chassis engage the tracks on the mounting brackets. Continue to slide the instrument into the cabinet until the front panel is flush with the cabinet panel. Turn the PANLOC buttons at the lower left and right corners of the instrument panel clockwise to lock the unit firmly in

the cabinet. Turn the PANLOC buttons counterclockwise to unlock the instrument. It can then slide outward to permit the removal of the instrument from the cabinet.

Fold out the photographs on the inside of the back cover. It will assist you in locating the controls and pushbuttons. The numbers and letters on the photographs refer to the paragraphs that follow.

There are four fields of audio connectors on the back panel of the C 34V for use with associated equipment: AUDIO INPUTS, EXTERNAL PROCESSORS, AUDIO OUTPUTS, and MONITOR AMPLIFIER. On the front panel are four additional phone jacks; two for use with an additional audio tape recorder and two for use with headphones.

Use shielded cables to interconnect the source equipment and the preamplifier. To minimize the possibility of hum or noise, the shielded cables should be of parallel construction or if not loosely twist the left and right cables together. Locate them away from the speaker connecting cables and AC power cords. Be certain to use good quality shielded cables for all interconnections. Your dealer can advise you on the kind and length of cable that will best suit your installation.

AUDIO INPUTS

1. TURNTABLE:

Connect the cable from the turntable left channel to the Left PHONO INPUT. Connect the cable from the turntable right channel to the Right PHONO INPUT. If the turntable has a separate ground lead, connect it to the screw terminal marked ground (GND).

2. TUNER:

Connect the cable from the tuner left channel output to the Left TUNER INPUT. Connect the cable from the tuner right channel output to the Right TUNER INPUT.

3. CD:

Connect the cable from the Compact Disc (CD) player left channel output to the Left CD INPUT. Connect the cable from the CD player right channel output to the Right CD INPUT.

4. TV:

Audio from a stereo TV set or TV monitor can be connected to the TV INPUT. Connect the left channel cable to the Left TV INPUT. Connect the right channel cable to Right TV INPUT.

The output of a monophonic TV set can be connected to both left and right channel TV INPUTS by use of a "Y" connector.

5. VCR 1/TAPE 1:

To Playback/Monitor: connect the cable from the tape recorder left channel output to the Left VCR 1/TAPE 1 INPUT. Connect the cable from the

tape recorder right channel output to the Right VCR 1/TAPE 1 INPUT. Connect a second and third recorder in the same manner to the VCR 2/TAPE 2 INPUT and LASER/TAPE 3 INPUT.

To Record: connect the cable from the Left VCR 1/TAPE 1 OUTPUT to the left high-level input of the tape recorder. Connect the cable from the Right VCR 1/TAPE 1 OUTPUT to the right input of the tape recorder. Connect a second and third recorder in the same manner to the VCR 2/TAPE 2 OUTPUT and TAPE 3 OUTPUT.

M. FRONT PANEL TAPE RECORDER JACKS:

TAPE 3 recorder input and output connections are also available at the TAPE 3 IN-OUT phone jacks on the front panel. The front panel phone jacks are designed for use with ¼-inch stereo phone plugs. Connections are tip: left signal, ring: right signal, and sleeve: common ground.

When a phone plug is inserted in the front panel TAPE 3 in phone jack, the circuit to the rear panel LASER/TAPE 3 INPUT is disconnected, but inserting a phone plug in the front panel TAPE 3 OUT phone jack does not disconnect the rear panel TAPE 3 OUTPUT. Thus, it is possible to record from the front panel TAPE 3 OUT phone jack and the rear panel TAPE 3 OUTPUT at the same time but it is not possible to listen to both at the same time.

6. VCR 1/TAPE 1 - VCR 2/TAPE 2:

Video Tape Recorders: If you prefer, one or both of the VCR/TAPE inputs can be used for the audio from a VCR. Connect the left channel audio output from the VCR to the Left VCR 1/TAPE 1 INPUT. Connect the right channel audio output from the VCR to the Right VCR 1/TAPE 1 INPUT. If the VCR has only a single audio output (mono), use a "Y" connector to connect the program to both the left and right input.

7. LASERVISION PLAYER:

The audio from a laser vision video disc player can be connected to the LASER/TAPE 3 INPUT if desired. Connect the cable from the left channel audio output of a laser disc player to the Left LASER/TAPE 3 INPUT. Connect the cable from the right channel audio output of a laser disc player to the Right LASER/TAPE 3 INPUT.

8. EXTERNAL PROCESSORS:

The second field of connectors are marked EXTERNAL PROCESSORS. There are two sets of EXTERNAL PROCESSOR jacks, one set that affects the program selected by the LISTEN selector and one set that af-

8 HOW TO CONNECT

fects the program selected by the RECORD selector. These jacks are used to add a noise reduction or any audio signal processing device. Be sure to match the left to left and right to right channels when connecting external processors.

The EXTERNAL PROCESSOR jacks have switching contacts which allow the signal to pass through them when there is nothing plugged into the jacks. When an external processor is used, the program is routed to the external processor from the EXTERNAL PROCESSOR TO jack and back by the EXTERNAL PROCESSOR FROM jack.

WHEN AN EXTERNAL PROCESSOR IS USED, IT MUST BE TURNED ON FOR THE PROGRAM TO BE HEARD THROUGH THE SYSTEM.

9. AUDIO OUTPUT:

The third field of connectors are marked AUDIO OUTPUT. Three sets of jacks (VCR 1/TAPE 1, VCR 2/TAPE 2, and TAPE 3) connect the program selected by the RECORD input selector. The MAIN set of jacks connect the program selected by the LISTEN input selector and connect to the power amplifier. Output to the two sets of jacks (SWITCHED 1 and SWITCHED 2) controlled by the front panel SPEAKER/OUTPUT 1 and 2 pushbuttons can be connected to additional power amplifiers for remote area listening.

The Left MAIN jack is to be connected to the amplifier left input jack. The Right MAIN jack is to be connected to the amplifier right input jack.

Two additional stereo power amplifiers may be connected in the same fashion to the SWITCHED OUTPUT jacks. Audio output signal is supplied to these jacks only when the front panel pushbutton SPEAKER/OUTPUT 1 and/or 2 pushbuttons are pressed in. This arrangement is useful to turn the program on or off to its separate amplifiers and loudspeakers.

10. MONITOR AMPLIFIER:

The MONITOR AMPLIFIER provides power to headphones. It may also be used to drive speakers. The MONITOR AMPLIFIER will furnish 20 watts per channel across 8 ohms or 12.6 volts RMS to a 600 ohm line. For operation, see MONITOR AMPLIFIER page 13.

The input to the MONITOR AMPLIFIER can be selected from either the RECORD program, the LISTEN program, or from a third source connected to the EXTERNAL INPUT jacks on the rear panel. The input selector switch is on the top panel of the C 34V.

The EXTERNAL INPUT May be used for program sources not originating in the C 34V. One use could be to connect the output of a time delay device for back channel speakers.

The output of the MONITOR AMPLIFIER is fed to the front panel HEADPHONE phone jacks, to the red and black *posicontact* push connectors and to the jacks marked OUTPUT. Connect the left speaker lead to the black COMMON push connector and the red L terminal. Connect the right speaker lead to the black COMMON push connector and the red R terminal.

The OUTPUT jacks can be connected to drive a low impedance (8 to 600 W) unbalanced line.

11. GROUND:

The ground (GND) post on the rear panel is provided primarily for a turntable or record changer that has a separate ground lead in addition to the signal leads.

12. AC POWER:

Plug the preamplifier AC power cord into a 120 volt 60 Hz wall outlet. The plug blades are polarized so be certain the plug is fully inserted in the outlet to prevent blade exposure.

CAUTION: TO PREVENT ELECTRIC SHOCK, DO NOT USE THE (POLARIZED) PLUG ON THIS UNIT WITH AN EXTENSION CORD, RECEPTACLE, OR OTHER OUTLET UNLESS THE BLADES CAN BE FULLY INSERTED TO PREVENT BLADE EXPOSURE.

Three types of AC power outlets are provided on the back panel of the C 34V. Three are black, two are red, and one is green.

The black outlets are switched on or off when the C 34V is turned on and off. Use these to provide AC power to amplifiers, CD players, or other accessories. The power capacity of all the outlets, totalled, is 1440 watts. The green outlet has a maximum capacity of 100 watts. For power consumption above 1440 watts, it is necessary to add a McIntosh SCR 2 (SPEAKER CONTROL RELAY). The SCR 2 has two AC power outlets that provide additional capacity of 1800 watts switched on or off by the C 34V. Use these outlets to supply AC power to amplifiers or other components whenever the total load to be switched exceeds the C 34V rating of 1440 watts.

The red outlets are on at all times and are used with accessories that have their own power switches. For example, a VCR should be plugged into one of these outlets for it to be able to record TV programs when the main audio system is turned off.

The green AC power outlet is on at all times and is used for turntable power. Do not use this outlet for any other purpose. When the turntable power cord is plugged into the green AC outlet, the turntable can be used as an alternate way to switch the AC power to the entire system on or off. When the turntable power is turned on, a sensor circuit in the C 34V will detect the current drain of the turntable motor and will turn on the C 34V the same way the red POWER pushbutton does. The red power pushbutton must be in the OFF or out position. As long as a turntable is connected to the green AC outlet, the turntable current will always override the red POWER pushbutton and turn the system on.

Some turntables draw the same or very nearly the same current whether on or off. AUTO TURN-ON control is not possible with this type of turntable. Use one of the red unswitched AC outlets instead of the green.

13. FUSE:

A 1.0 AMP fast-acting fuse protects the C 34V turntable current sensing circuits and the green AC turntable outlet. This fuse must be replaced with the same type and rating 1.0 AMP fast-acting fuse. Do not use SLO BLO fuses. The fuse does not protect equipment connected to the black AC outlet.

14. OPTIONAL ACCESSORIES:

ADDITIONAL AC POWER AND SPEAKER SWITCHING WITH THE SPEAKER CONTROL RELAY

The SPEAKER CONTROL RELAY, or SCR 2, is designed to provide both speaker control switching and high power switched AC outlets.

The SCR 2 also has two AC power outlets that provide additional capacity of 2400 watts switched by the C 34V. Use these outlets to supply AC power to amplifiers or other components when the total load switched exceeds the C 34V rating of 1440 watts. Plug the 4-prong plug on the cable attached to the SCR 2 into the SCR 2 socket on the rear of the C 34V. Plug the SCR 2 heavy, AC power line cord directly into a wall outlet. Do not plug it into the C 34V. When the C 34V is turned on, power from the C 34V will energize a relay in the SCR 2 which connects the two SCR 2 AC outlets directly to the wall outlet.

Two loudspeakers can be turned on or off with the SCR 2 by using the front panel pushbuttons SPEAKER/OUTPUT 1 and 2. Use the TO MAIN SPEAKERS terminal strip to connect the main listening pair of

speakers and TO REMOTE SPEAKER terminal to a remote area pair of speakers. Connect the power amplifier output to FROM POWER AMPLIFIER terminal strip. Maintain left and right orientation and like polarity. Pushbutton SPEAKER 1 will turn the main speakers on or off and SPEAKER 2 pushbutton will turn the remote speakers on or off.

15. VIDEO SELECTOR:

The McIntosh VIDEO SELECTOR, MVS-1, is designed to enable the C 34V to control video programs as well as audio. The MVS-1 connects to the VIDEO SELECTOR computer-type connector on the rear of the C 34V. Follow the instruction packet with the MVS-1 for connecting the video cables,

10 HOW TO CONNECT

Fold out the photographs on the inside of the back cover. It will assist you in locating the controls and pushbuttons. The letters on the photographs refer to the paragraphs that follow.

Before attempting to operate your C 34V Audio/Video Control Center, familiarize yourself with the controls and what they do.

A. LISTEN AND RECORD SELECTOR SWITCHES

The LISTEN Input selector switch is located at the upper left on the front panel. It is used to select the input for the LISTEN program line. The selected program source is fed to the MAIN output.

The RECORD input selector switch is located at the lower left on the front panel. It is used to select the input for the RECORD program line. The selected program source is fed to the TAPE 1, TAPE 2, and TAPE 3 outputs. The RECORD and LISTEN switches operate totally independently of each other and without any interference.

B. MODE SELECTOR

The MODE SELECTOR allows you to identify each stereo channel, create monophonic program material, and direct program material to one channel or the other. The MODE SELECTOR operates only in the LISTEN program line.

It controls the program in seven ways:

L TO L&R: Connects the left input to both left and right output circuits.

R TO L&R: Connects the right input to both left and right output circuits.

STEREO REV: Connects the left input to the right output circuit and the right input to the left output circuit.

STEREO: Connects the left input to the left output circuit and the right input to the right output circuit. Use the STEREO position for normal listening.

MONO (L + R): Adds the left to the right input and connects the composite to both left and right output circuits.

L + R TO L: Connects the left plus right program to the left output circuit only.

L + R TO R: Connects the left plus right program to the right output circuit only.

C. EQUALIZER FREQUENCY CONTROLS

Each of five EQUALIZER FREQUENCY controls raises or lowers the amplitude of a band of frequencies centered on the frequency marked above the control. Both left and right channels are affected. The center, or flat position of the control has a detent for easy reference. In the center or detent position, the entire circuit for that control is removed

from the program circuit by grounding the control electronically. The result is the "straight wire with gain" or the flexibility of complete musical balancing to your taste.

Use the EQUALIZER FREQUENCY controls to modify the sound and balance of program material.

Here are some suggestions:

<u>Adjustment to</u>	<u>Equalizer Correction</u>
Make deep bass louder	Raise 30
Make all bass louder	Raise 30 and 150
Reinforce voices	Lower 150 and raise 500
Hum on program	Reduce 30 and 150
Brighten violins and trumpets	Raise 1500
Emphasize cymbals	Raise 10 K

The EQUALIZER FREQUENCY controls can be switched to either the LISTEN or RECORD program lines by the RECORD EQUALIZER pushbutton. Because the equalizer is in the circuit after the COMPANDOR, use of the equalizer will not affect the performance characteristics of the COMPANDOR.

D. BALANCE AND LOUDNESS

The BALANCE and LOUDNESS controls are concentric. The BALANCE control (large outer knob) adjusts the volume of the channels relative to each other.

L-left...turning the control to the left accents the left channel by reducing the right channel output.

R-right...turning the control to the right accents the right channel by reducing the left channel output.

E. LOUDNESS

The LOUDNESS control (small center knob) provides frequency response contoured to compensate for the behavior of the human ear at lower listening levels. This contour is accurately modeled after the family of "equal loudness" curves identified by Fletcher and Munson. At the fully counterclockwise detented FLAT position, the loudness contour is electrically flat. As the control is turned clockwise, both bass and treble frequencies increase in the correct proportion. The contour is not affected by different settings of the VOLUME control. After setting the VOLUME control for the desired listening level, adjust the LOUDNESS control for the preferred compensation.

F. COMPANDOR SYSTEM:

The McIntosh COMPANDOR System can be used to control the dynamic range of program material. It can be used in two different ways: to function as an

expander or as a compressor. Expansion can restore the dynamic range limited by the process of recording both records and tape or broadcasting of music. Compression decreases dynamic range. It can be used for making tape recordings or for listening to background music. The Compandor can be switched to either the RECORD or LISTEN lines, by means of the COMPANDOR pushbutton.

The Compandor System has four controls. The concentric three-position COMPANDOR switch and RATIO control are located on the front panel. The LEVEL MATCH control and SPEED selector are located on the C 34V top panel.

COMPANDOR SELECTOR

The outer COMPANDOR knob can be set to EXPAND, OFF, or COMPRESS. When the COMPANDOR switch is in EXPAND or COMPRESS, a red light will appear above the LISTEN or RECORD COMPANDOR pushbutton. In the center OFF position, the Compandor System is switched out of the circuit and the lights will be out. When the Compandor is not used, the selector should be placed in the OFF position.

RATIO CONTROL

The inner RATIO knob is used to control the amount of expansion or compression.

LEVEL MATCH

The LEVEL MATCH control on the top panel is used to adjust the listening level when the expander or compressor is switched in or out of the circuit.

SPEED

The SPEED selector on the top panel is used to control the rate at which the Compandor System responds to signals. By switching from FAST to NORMAL to SLOW, a more gradual rate of change in expansion or compression occurs. For music with percussive instruments, such as piano, drums, guitar, etc., use NORMAL or FAST. In the FAST mode, the Compandor System follows changes quickly but will track low frequencies less accurately. Non-percussive music and voice require slower speed. At SLOW speed the low frequency tracking is accurate, but the rate of response is slower. The NORMAL position is best suited for most program material.

USING THE COMPANDOR AS AN EXPANDER

When the COMPANDOR selector switch is in the EXPAND position, the RATIO control is used to select the amount of expansion. Full counterclockwise rotation corresponds to a ratio of 1.0. This

means that the dynamic range of the expander output is the same as the dynamic range of its input. With the VOLUME control at a normal listening level, the RATIO control is turned clockwise, the output dynamic range becomes greater than the input. Set the RATIO control to the desired expansion (usually between 1.2 and 1.5). Now switch the COMPANDOR selector knob between EXPAND and OFF. A change in the average listening level will usually be heard. Adjust the LEVEL MATCH (on the top panel) control until the average listening levels match as closely as possible when in EXPAND and OFF. After this adjustment, you will notice that with the expander on, loud passages will be louder and soft passages will be softer tending to make any background noise quieter.

When the RATIO control is at the fully clockwise position, it corresponds to a ratio of 2.0. The output dynamic range is then twice the input dynamic range. This setting is extreme for most program material.

USING THE COMPANDOR AS A COMPRESSOR

When the COMPANDOR selector switch is in the COMPRESS position, the RATIO control is used to select the reduction in dynamic range desired. Full counterclockwise rotation corresponds to a ratio of 1.0. The compressor output and input dynamic range will be the same. Set the VOLUME control to a normal listening level. As the RATIO control is turned clockwise, the output dynamic range becomes less than the input range. Set the RATIO control to the desired amount of compression. Switch the COMPANDOR selector knob between COMPRESS and OFF. A change in the average listening level will usually be heard. Adjust the LEVEL MATCH control until the average listening levels match as closely as possible when switching between COMPRESS and OFF. After this adjustment, you will notice that with COMPRESS on, loud passages will be softer and soft passages will be louder.

When the RATIO control is at the fully clockwise position it corresponds to a ratio of 2.0. The output dynamic range is then one half of the input range. This setting can be useful to create highly compressed tape recordings particularly useful in noisy locations such as automobiles, etc.

Two examples for using the expander are:
1. To reduce background noise (hum, hiss or scratch):

- a. Select the desired program source with the

12 FRONT PANEL CONTROLS

LISTEN input selector.

b. Increase the VOLUME control during a quiet passage of the program until noise is clearly audible.

c. Turn the COMPANDOR selector knob to EXPAND. The Listen indicator will light over the COMPANDOR pushbutton.

d. Rotate the RATIO control clockwise until the noise is acceptably reduced.

e. Adjust the LEVEL MATCH control as previously described.

2. To improve the sound of recorded or broadcast

program material:

a. Select the input on the LISTEN input selector.

b. Increase the VOLUME to a satisfactory level.

c. Turn the COMPANDOR selector switch to

EXPAND.

d. Rotate the RATIO control clockwise until the dynamic range of the music is satisfactory for you.

The usual position will be between 1.2 and 1.5.

e. Adjust the LEVEL MATCH control as previously described.

TOP PANEL CONTROLS

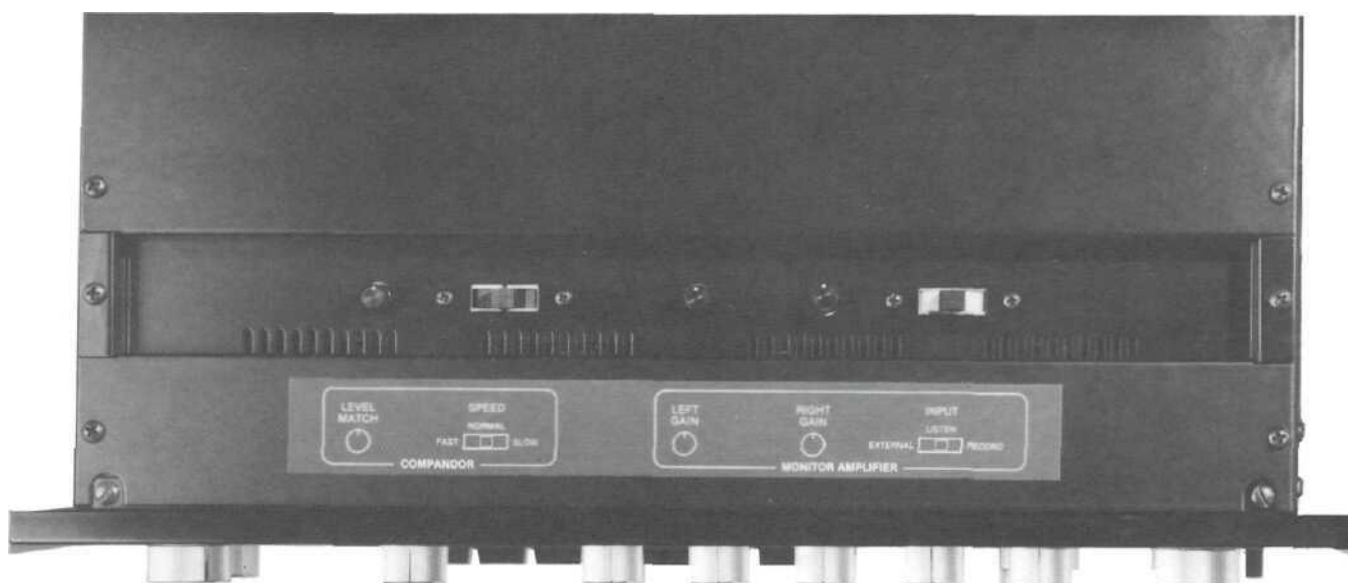

COMPANDOR

Operation of the LEVEL MATCH and SPEED controls is explained on page 12. See the Compandor System description.

MONITOR AMPLIFIER

The built-in MONITOR AMPLIFIER can drive headphones, loudspeakers, or provide a low impedance line output. A top panel input position switch selects the input for the MONITOR AMPLIFIER. The sources are the LISTEN program line, the RECORD program line, or any high level EXTERNAL source. When using headphones plugged into the front panel jacks, the normal position is LISTEN.

The monitor amplifier LEFT and RIGHT GAIN controls are located to the left of the INPUT switch on the top panel. When the switch is in the LISTEN position, the

LEFT and RIGHT GAIN controls regulate the monitor volume along with the main front panel VOLUME control. When the INPUT switch is in the RECORD or EXTERNAL position, only the LEFT and RIGHT GAIN controls regulate the monitor amplifier volume.

The monitor amplifier can be used with any low impedance dynamic headphones. High impedance headphones will work but at reduced listening levels.

G. COMPANDOR

The COMPANDOR pushbutton switches the COMPANDOR circuits between the LISTEN (out position) and RECORD (in position) program lines or disconnects the circuit entirely. A red light emitting diode (LED) illuminates to indicate when the circuit is connected to either Listen or RECOrd. When neither is lit, the COMPANDOR selector knob is turned to the OFF position.

H. RECOrd EQUAL

The EQUALIZER FREQUENCY pushbutton connects these controls to the LISTEN or RECORD program lines. When the pushbutton is out, the EQUALIZER FREQUENCY controls are connected to the LISTEN line, and the red LED indicator above the button is off. When the pushbutton is in, they are connected to the RECORD line. The red LED indicator will be on. The normal position is with the pushbutton out.

I. RECOrd MONITOR

To monitor while recording with a three-head tape recorder, set the LISTEN input selector to the proper TAPE position. The RECOrd MONITOR LED indicator is off when listening to the program recorded on the tape and on when listening to the program source being fed to the tape recorder.

J. LF FILTER

The Low Frequency FILTER is in the LISTEN program line only. When the pushbutton is out, the filter is out of the circuit and the red indicator light will be off. When the pushbutton is in, the LF FILTER is in the circuit and the red light will be on. The filter is effective for all frequencies below 50 Hz and attenuates at the rate of 12 dB per octave. Use it to reduce undesirable low frequency noise such as rumble or mechanical feedback.

K. HF FILTER

The High Frequency FILTER is in the LISTEN program line only. When the pushbutton is out, the HF FILTER is out of the circuit and the red indicator light is off. When the pushbutton is in, the HF FILTER is in the circuit and the red light is on. The filter is effective for all frequencies above 7,000 Hz and attenuates at the rate of 12 dB per octave. Use it to reduce undesirable high frequency noise such as record surface noise or tape hiss.

L. SPEAKER/OUTPUT 1 and 2

The SPEAKER/OUTPUT 1 and 2 pushbuttons can be used to switch on or off either the AUDIO OUTPUT SWITCHED 1 and 2 jacks or the main and

remote speakers when an optional Speaker Control Relay (SCR 2) is used.

The SWITCHED 1 and 2 jacks on the rear panel of the C 34V have the same program as the MAIN OUTPUT. When one or both SPEAKER/OUTPUT pushbuttons are IN, the LISTEN program line is connected to the corresponding pair of OUTPUT jacks and the LED indicator is turned on. Program to other devices can be controlled such as rear channel delay, reverberation, etc. Example: connect the SWITCHED 1 jack to the input of a reverberation device and the output of the reverberation device to the input C 34V MONITOR AMPLIFIER and the output of the MONITOR AMPLIFIER to a set of rear loudspeakers. (The monitor amplifier switch must be in the EXTERNAL position.) Rear channel reverberation can then be switched on or off by the SPEAKER OUTPUT 1 pushbutton without the need for an additional amplifier.

N. POWER ON

The red pushbutton turns the C 34V on or off. When the power is on, the panel illuminates and the red light above this pushbutton will go on. The turntable can also be used as a power switch. See page 10.

14 PUSHBUTTONS

PERFORMANCE LIMITS

Performance limits are the maximum deviation from perfection permitted for a McIntosh instrument. We promise you that when you purchase a new C 34V from a McIntosh franchised dealer, it will be capable of or can be made capable of performance at or exceeding these limits or you can return the unit and get your money back. McIntosh is the only manufacturer that makes this statement.

PREAMPLIFIER SECTION

FREQUENCY RESPONSE

+ 0, -0.5dB from 20Hz to 20,000Hz

MAXIMUM VOLTAGE OUTPUT

10 volts from 20Hz to 20,000Hz

TOTAL HARMONIC DISTORTION

0.01% maximum from 20Hz to 20,000Hz at rated output

SENSITIVITY

Phono- 2mV for 2.5V rated output (0.4mV IHF)

High Level- 250mV for 2.5V rated output (50mV IHF)

SIGNAL TO NOISE RATIO, A-WEIGHTED

Phono- 90dB below 10mV input (84dB IHF)

High Level- 100dB below rated output (86dB IHF)

MAXIMUM INPUT SIGNAL

Phono- 100mV

High Level- 10 volts

INPUT IMPEDANCE

Phono- 47k ohms and 65pf capacitance

High Level- 50k ohms

EQUALIZATION CONTROLS

Variable 12dB boost to 12dB cut at center frequencies of 30, 150, 500, 1500, 10k Hz

COMPANDOR RATIOS

From 1:2 compression to 2:1 expansion

LF FILTER

Flat or roll-off at 12dB per octave below 50 Hz.

HF FILTER

Flat or roll-off at 12dB per octave above 7,000 Hz.

MONITOR AMPLIFIER SECTION

CONTINUOUS AVERAGE POWER OUTPUT

20 watts per channel into 8 ohms, from 20Hz to

20kHz, at 0.01% maximum harmonic distortion

FREQUENCY RESPONSE

+ 0 -0.2dB from 20Hz to 20,000Hz

SENSITIVITY

750mV for rated output (170mV IHF), input impedance is 27K ohms

SIGNAL TO NOISE RATIO, A-WEIGHTED

100dB below rated output (87dB IHF)

GENERAL INFORMATION

SEMICONDUCTOR COMPLEMENT

31 Bipolar Transistors

76 Field Effect Transistors

35 Integrated Circuits

107 Diodes

1 Silicon Controlled Rectifier (SCR 2)

AC POWER OUTLETS

1 green turntable current sensing, 100 watts

2 red unswitched

3 black switched

1440 watts total capacity

POWER REQUIREMENTS

120 volts, 50/60 Hz, 25 to 85 watts

MECHANICAL INFORMATION

SIZE:

16-1/8 inches wide (40.6 cm) by 5-7/16 inches high (13.8 cm) by 13 inches deep (33 cm), from the mounting surface, including PANLOC shelf and back panel connectors. Knob clearance required is 1-1/4 inches (3.2 cm) in front of the mounting panel.

FINISH:

Front panel is anodized gold and black with special gold/teal nomenclature illumination. Chassis is black.

MOUNTING:

Exclusive McIntosh developed professional PANLOC

WEIGHT:

26 pounds (11.8 kg) net, 38 pounds (17.2 kg) in shipping carton

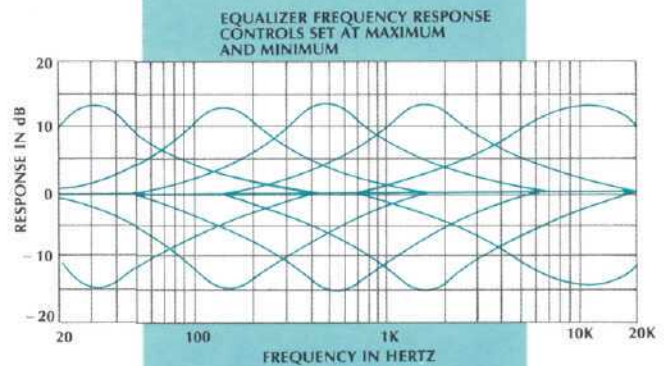
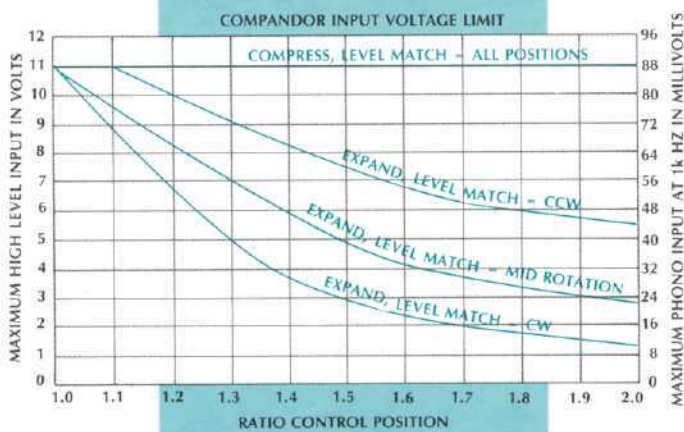
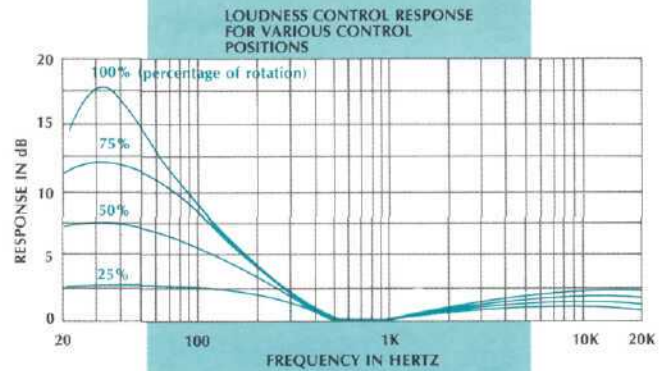
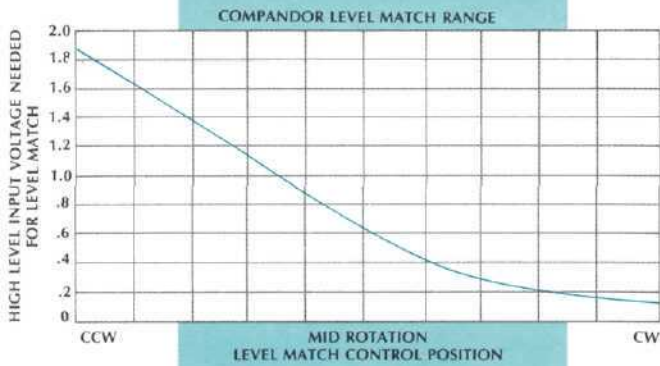
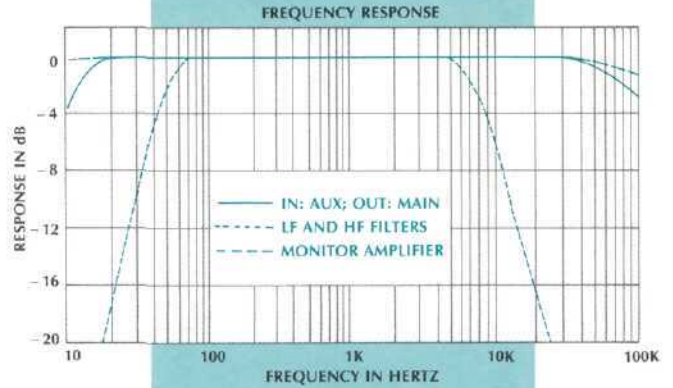
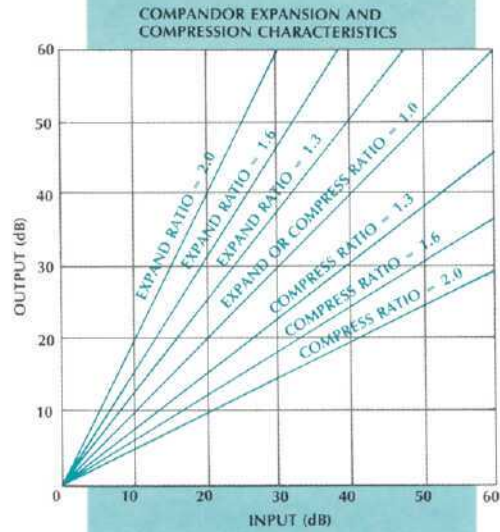

16 PERFORMANCE CHARTS

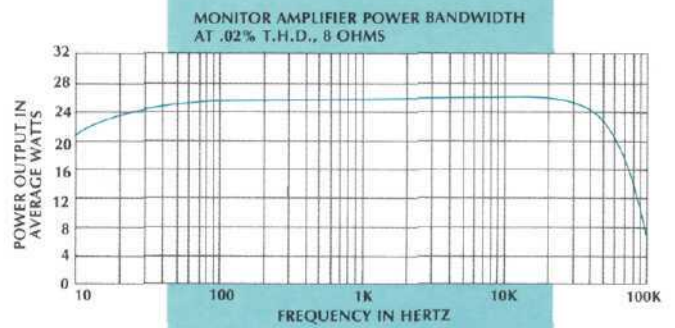
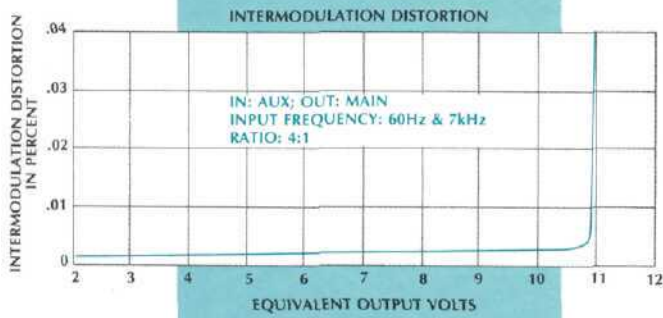
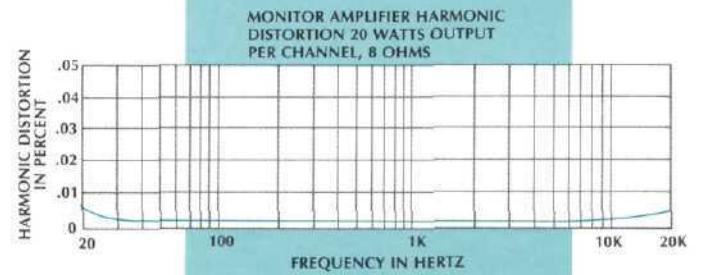
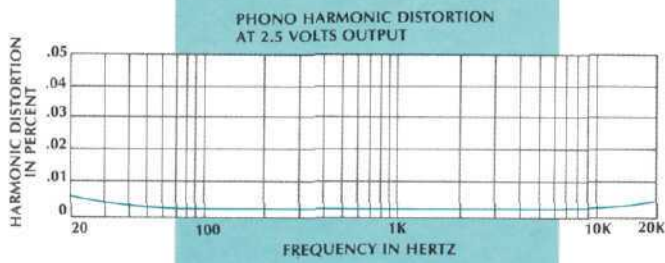
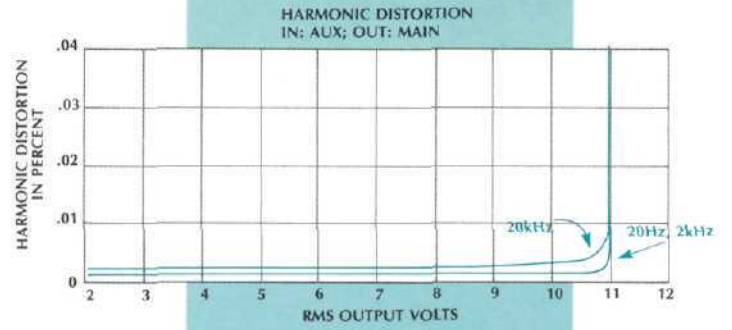
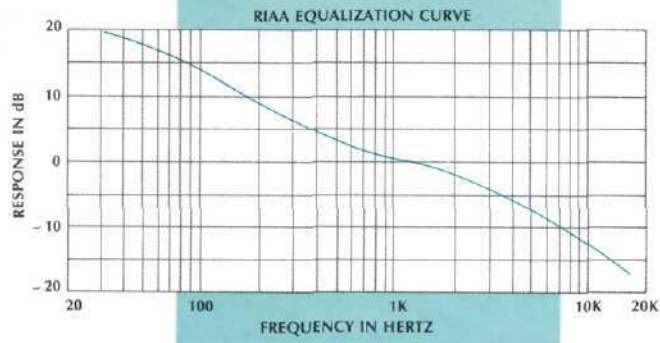

PERFORMANCE CHARTS 17

The simplified block diagram on page 5 and the detailed block diagram on pages 20 and 21 show how the C 34V internal circuits are arranged. The C 34V uses separate program channels (referred to as "program lines" in this manual) for "listening" and "recording". This allows you to listen to any program source while you record from another or the same program source. The mode selector, volume control, loudness control, balance control, and LF and HF filters are in the listen program line only. The compandor, the five equalizer frequency controls, and the monitor amplifier can be individually switched to the listen program line or the record program line.

PHONO AMPLIFIER

This amplifier uses a high technology integrated circuit operational amplifier. Its differential input stage has been optimized for low noise and low distortion performance. Open loop gain of this integrated circuit is 100,000 times. With high open loop gain a large amount of negative feedback is used around the phono amplifier to further reduce noise and distortion. The feedback network also provides precision RIAA frequency compensation. The network uses 1% metal film resistors and 5% poly film capacitors. To achieve low noise performance it is essential that the feedback network have very low impedance. As a consequence, the pre-amplifier must be capable of operating as a power amplifier to drive this impedance. The actual power output capability of this preamplifier stage is more than 100 milliwatts, a great margin beyond that which is required.

Input sensitivity of the phono amplifier is 2.2 millivolts. The gain of the amplifier is 42 dB at 1000 Hz. The phono amplifier has a very wide dynamic range. At 1000 Hz the phono input circuit will accept 100 millivolts without overload, a voltage far greater than the output of any magnetic phono cartridge presently available.

LISTEN AND RECORD SELECTOR SWITCHES

Input switching is accomplished electronically. Signals from the 7 inputs connect to two arrays of Field Effect Transistors (FET) to perform the switching. Control signals from the listen and record selector switches turn on the appropriate FET switches to pass the selected input signals. The other input signals are blocked by the "off" FET switches. Each FET switch uses two cascaded FET transistors to provide the required isolation and prevent cross talk between inputs. The FET "on" resistance is very low which prevents distortion. The switching transistors are located right at the input jacks, so that

signal wiring is kept to a minimum which eliminates cross talk and noise problems.

LISTEN PROGRAM LINE

The listen program signal from the LISTEN input switch goes to the COMPANDOR control switching where the COMPANDOR can be inserted in either the listen or the record program path. The COMPANDOR circuit is described later.

The listen program then goes to the LISTEN EXTERNAL Processor jacks. When an EXTERNAL PROCESSOR is used, the listen program leaves the C 34V through the EXTERNAL processor TO jack and returns via the FROM jack. If a processor is not used, the signal passes directly through the switching contacts in the jacks.

The volume control is next in the listen path. It is a step attenuator with left to right tracking accuracy better than 1 dB throughout its entire range. Such extremely accurate matching is achieved through electronically controlled trimming of the resistance material deposited on pairs of printed circuits within the control. Since the switch commutator touches only contact pads and not the actual resistance element, tracking accuracy is not degraded with use as in ordinary volume controls.

The loudness control and its amplifiers follow the volume control. In the past, loudness controls have typically been simple passive circuits connected to a tap on the volume control. As a consequence, compensation accuracy was dependent on many variables such as volume control position and differences in the input level. The C 34V loudness control uses active circuits of an integrated circuit operational amplifier with two feedback loops. One has flat frequency response, while the other has response conforming to the Fletcher-Munson equal loudness contours. A potentiometer is placed between these two feedback loops making it possible to select any combination of the two, from a flat response to full loudness compensation. The overall gain of the stage is 20 dB at mid-frequencies and the average listening volume is not affected by the position of the loudness control.

The listen program signals next pass to the balance control and then to the equalizer amplifier composed of a low noise operational amplifier with flat response and unity gain. Five other operational amplifiers are arranged in circuit configurations that are equivalent to five series tuned circuits, each at one of the equalizer frequencies. These series tuned circuits are inserted via control potentiometers into either the input circuit or feedback circuit of the equalizer amplifier to provide a boost or cut capability of 12 dB for each equalizer band

18 TECHNICAL DESCRIPTION

of frequencies. A pushbutton switch allows the equalizer circuit to be switched from the listen program line to the record program line.

The LF and HF Filters follow the equalizer amplifier. These are active filters using operational amplifiers. When switched in, the LF filter attenuates frequencies below 50 Hz at a rate of 12 dB per octave. The HF Filter attenuates frequencies above 7 kHz at a rate of 12 dB per octave.

The listen program signal then is fed to the main output jacks. The OUTPUT 1 and OUTPUT 2 jacks receive the same signal but can be turned on or off by the Speaker/Output 1 and 2 pushbuttons.

RECORD PROGRAM LINE

The RECORD program signal from the RECORD input switch goes first through a unity gain amplifier and then to the COMPANDOR switching where the Compandor can be inserted into the record program path. The Compandor circuit is described later. The record program then goes to the RECORD EXTERNAL PROCESSOR jacks. These jacks, like the LISTEN EXTERNAL PROCESSOR jacks, have switching contacts so that the signal passes through when plugs are not inserted in the jacks. When an external processor is used, the record program leaves the C 34V through the EXTERNAL PROCESSOR TO jack and returns via the FROM jack. When a processor is not connected, the signal passes directly through the jacks.

An equalizer amplifier with unity gain follows. A pushbutton switch allows the 5 band equalizer controls to be switched from the Listen program line to the Record program line. This feature allows equalizing the record signal before it is fed to a recorder.

The equalizer amplifier feeds to electronic interlock switching and then finally to the record output jacks. The switching is arranged so that if the Record input selector is positioned to select the output of a recorder, the Record program line will not feed the record output jack connected to that recorder. This prevents recorder feedback.

COMPANDOR

The Compandor will expand or compress the dynamic range of the program material. The Compandor can be switched to the Listen or Record program lines or turned off. Program to the Compandor is applied to a voltage controlled amplifier (VCA) which operates as a variable gain block. Control voltages for this VCA are developed from a sample taken from the left and right channel input signals to the VCA. The electronic processing of this sample is detailed. It in-

cludes band shaping, logarithmic conversion, full wave rectification, level setting, expansion or compression ratio regulation, attack timing, and DC amplification. The resulting processed voltage controls the gain of the VCA to cause logarithmic gain expansion when expanding the program, or the opposite, logarithmic gain compression when compressing the program.

MONITOR AMPLIFIER

The monitor amplifier is a 20 watt per channel stereo power amplifier. The monitor input selector switch allows the amplifier to be driven from the LISTEN or RECORD program lines or from an external input. It is a push pull complementary class AB amplifier using a differential input stage. The amplifier includes the McIntosh Power Guard* protection circuit. The Power Guard circuit compares the amplifier output signal with its input signal. If there is a difference between the waveforms of these signals, Power Guard activates an electronic attenuator at the input of the amplifier which reduces the amplifier input level. This automatic control system makes it impossible to drive the monitor amplifier into clipping. Thus, clipping distortion and loudspeaker damage due to clipping are eliminated.

AUTO TURN-ON

A turntable plugged into the green outlet at the rear of the C 34V can control the on-off operation of the C 34V. Current flow to the turntable is sensed and controls a silicon control rectifier (SCR). When the SCR conducts a relay closes. This relay turns on power to the C 34V and to the black AC power outlets. Power is also controlled by the C 34V Power On pushbutton.

•protected by US Patent #4048573)

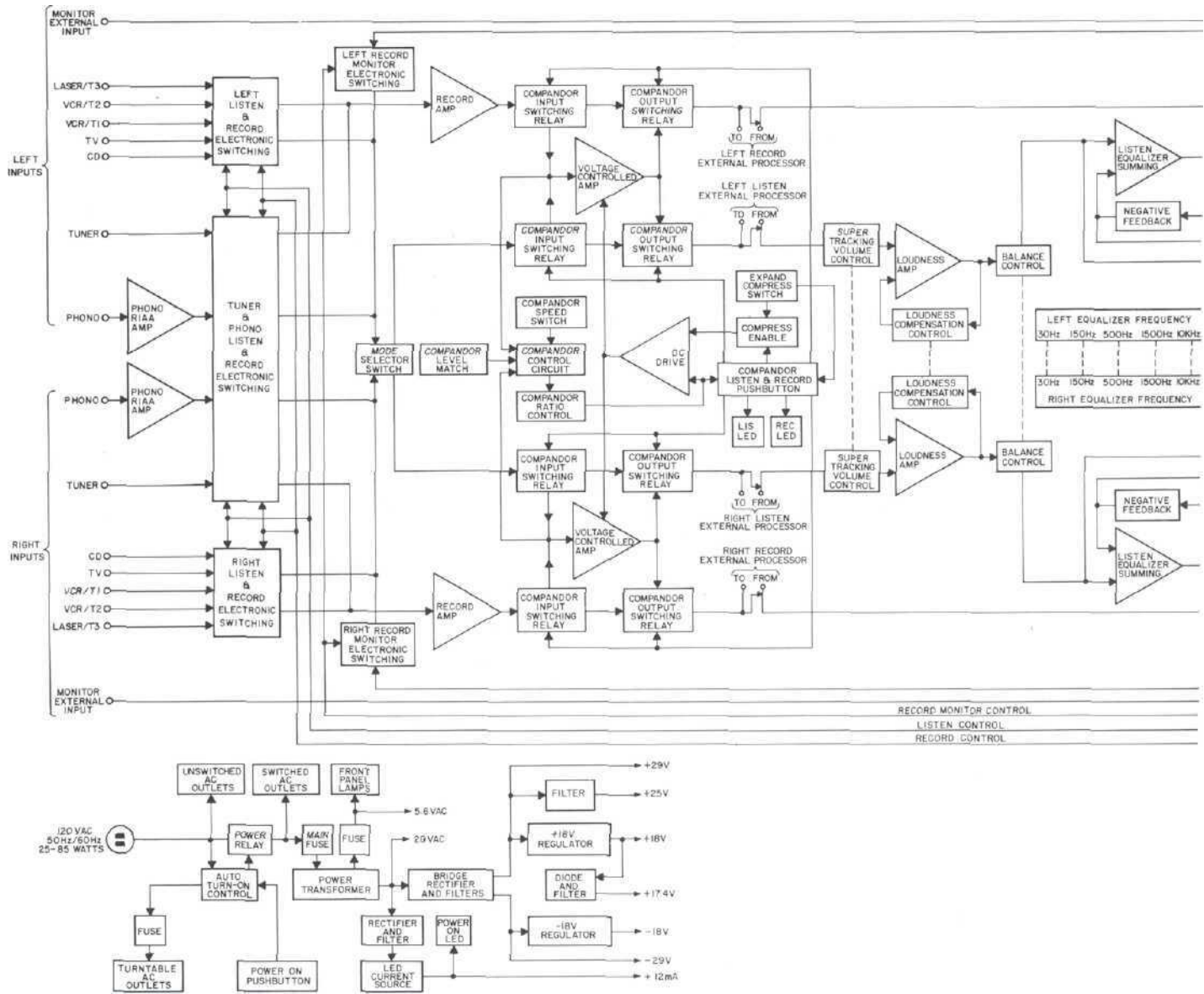

C 34V

20 BLOCK DIAGRAM

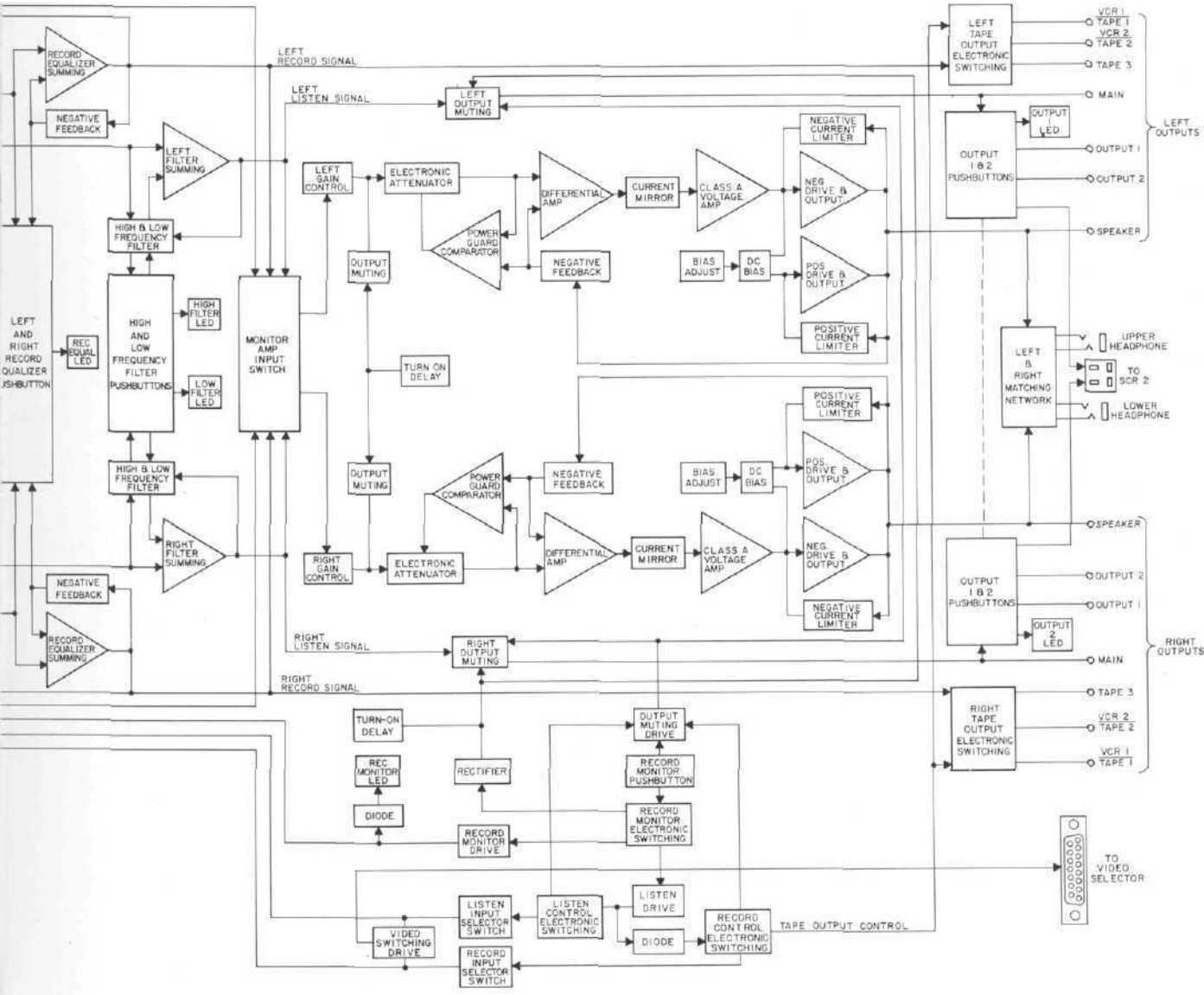

BLOCK DIAGRAM 21

THE LOCATION OF CONTROLS AND PUSHBUTTONS

The numbers and letters correspond to the paragraphs on pages 8, 9, 10, 11 and 12.

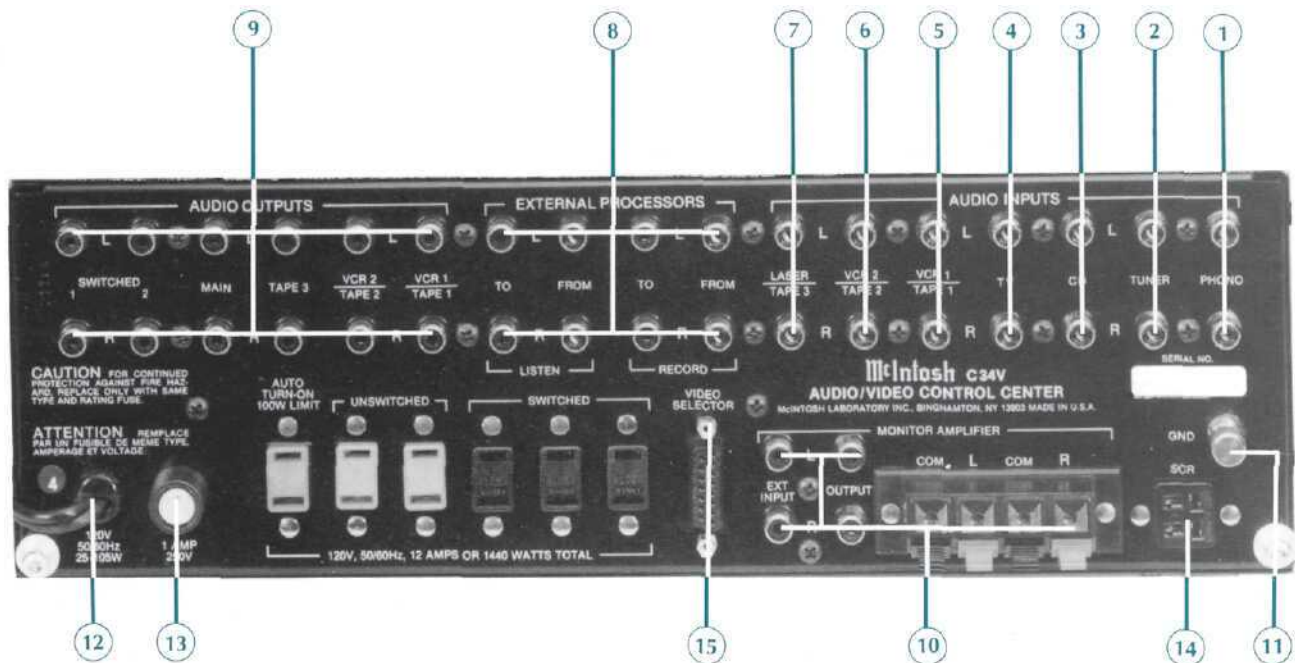
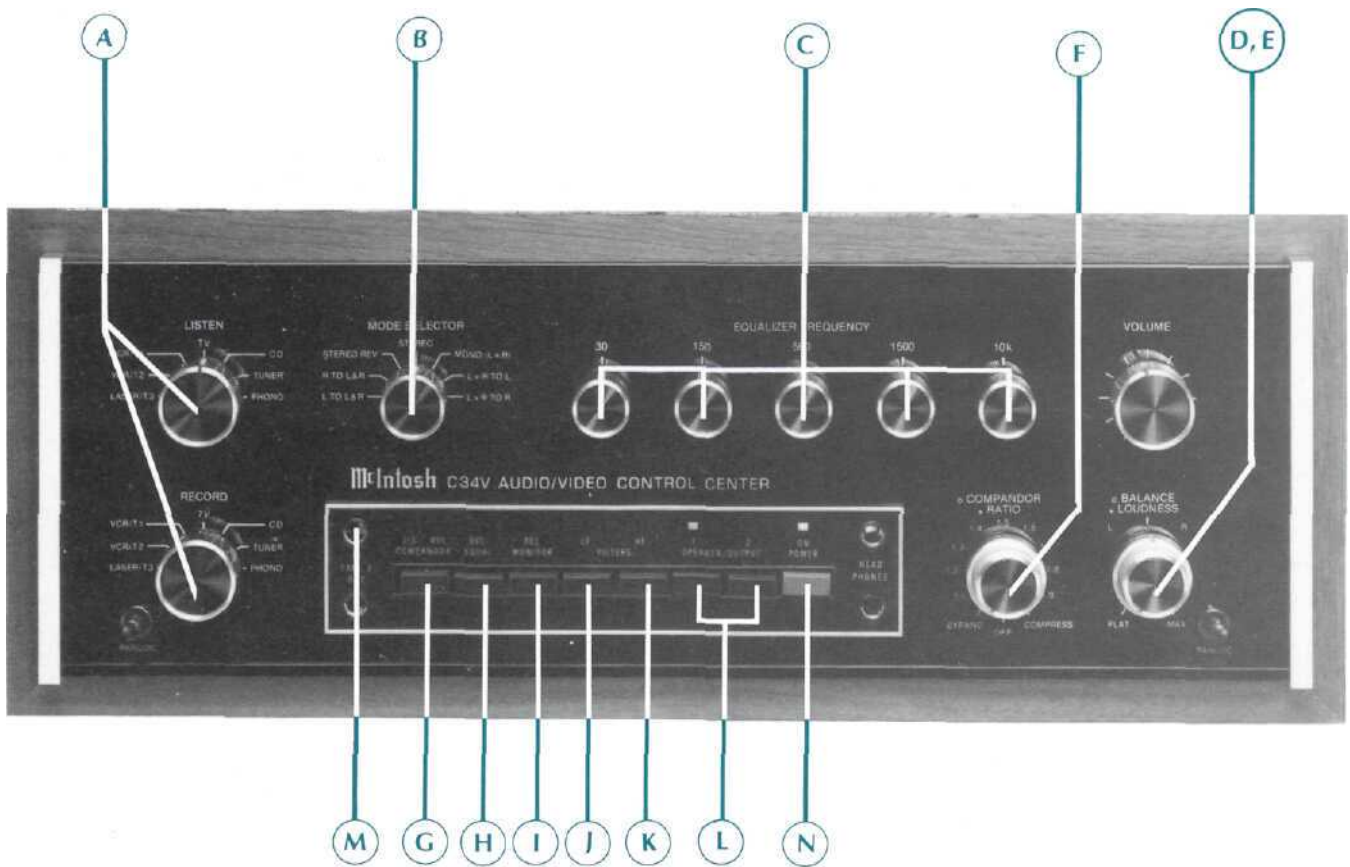

McIntosh®

McINTOSH LABORATORY INC.
2 CHAMBERS ST., BINGHAMTON, NY 13903-2699
607-723-3512

*The continuous improvement of its products is the policy of
McIntosh Laboratory Incorporated who reserve the right
to improve design without notice
Printed in U.S.A.*

039696